

Type 55-01-10 Weigh Module

7.5 t...22.5 t



Weigh Module 55-01-10 with RC3 Load Cell



Pre-assembled module

Flintec load cell supports are designed to prevent unwanted forces from affecting load cell performance.

The Type 55-01-10 is a self aligning weigh module, with excellent load introduction.

The module is especially designed for using Flintec rocker column load cells in hopper and tank weighing applications. The module incorporates an integrated bumper stop eliminating the need for check links thereby offering highest possible precision.

The Weigh Module will be shipped pre-assembled; ready for installation by bolting or welding.

Material: steel, zinc plated; alternatively stainless steel.

Important Features

- Capacities 7.5 t, 15 t and 22.5 t.
- Very easy to install.
- Very rugged.
- Especially designed for hopper and tank weighing.
- Integrated bumper stop for highest accuracy.
- Integrated lift off protection.
- Load cell replacement requires minimum lifting height.
- W&M certified.

Dimensions

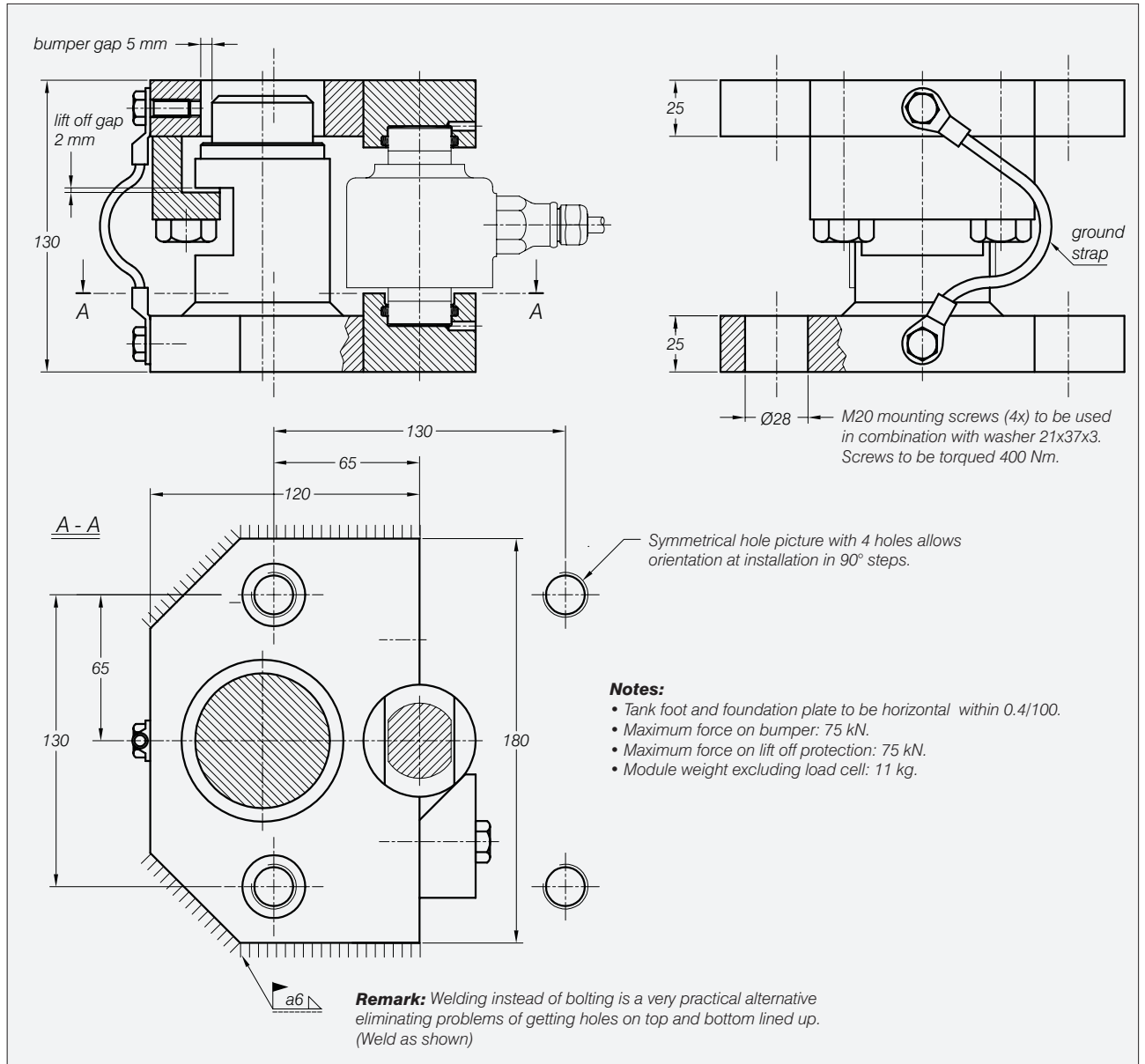

All dimensions in mm. Dimensions and specifications are subject to change without notice. Assembly drawings with installation instructions and CAD files for customer's own applications are available on request.

Module assembled for shipment and installation

