

## Type 52-01HD Weigh Module

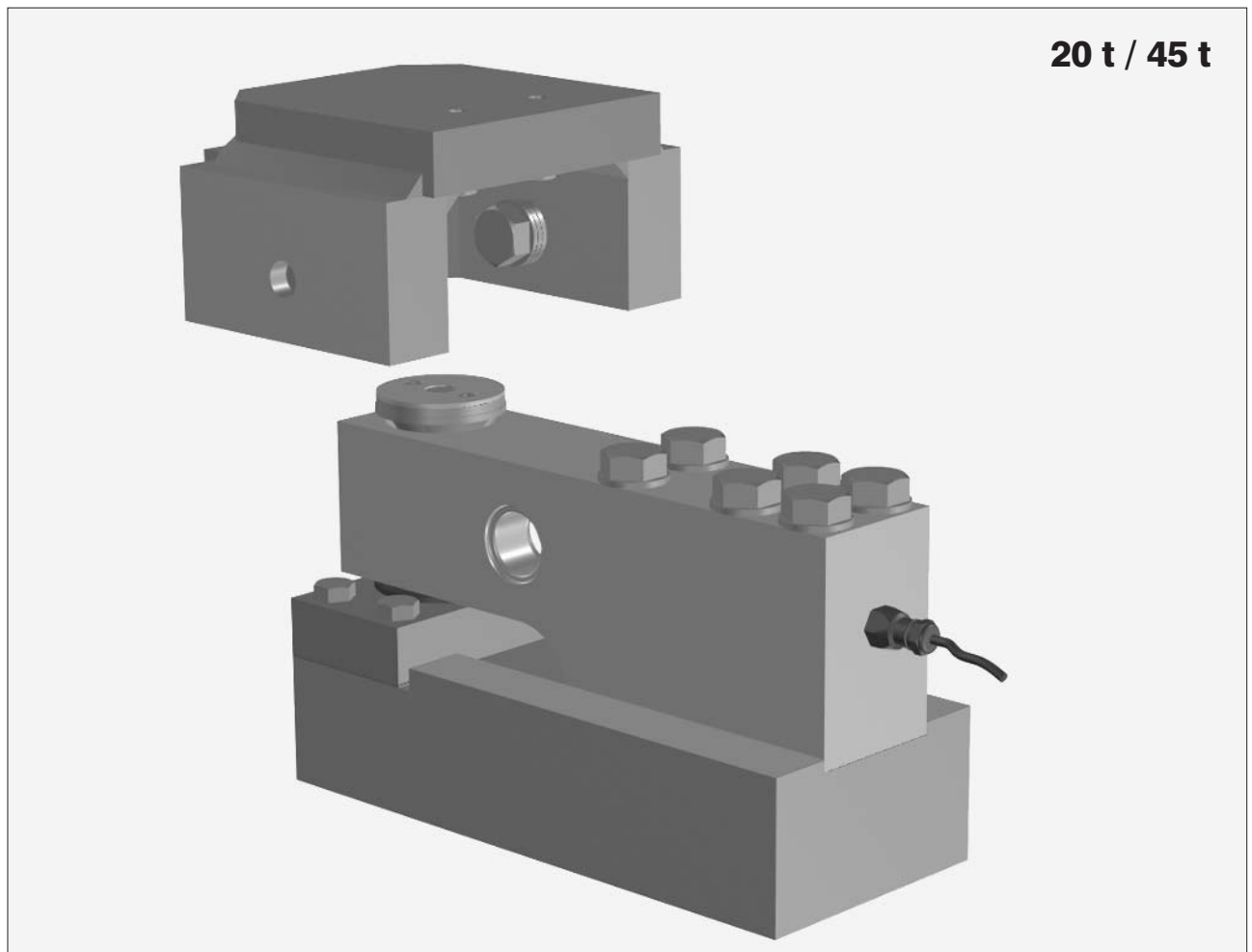

Weigh Module Type 52-01HD with SB2 load cell

Flintec load cell supports are designed to prevent unwanted forces from affecting load cell performance.

The type 52-01HD weigh module with type SB2 load cell is designed for high capacity, heavy duty, platform scales. It is especially well suited for scales in the steel industry. For example ladle and scrap basket scales where the load is handled with crane on and off the scale and frequent overloading occurs.

For scrap basket scales the built in overload stop efficiently protects the load cell from impact loads when scrap is loaded and being dropped from sometimes several meters height into the basket.

Available as 3-directional bumper module resp. free sliding module.

The bumpers of the 3-directional module can be rearranged to achieve a number of different bumping configurations. See examples on page 2(2).

A machined slot in the base plate prevents the load cell from sliding when subjected to high side forces.

An overload stop can be added as an option and protects the load cell from overloads up to at least 500% of rated load.

Material: Mild steel, painted.

### Important Features

- Capacities: 20t and 45t.
- Ideal for high capacity, heavy duty, platform scales.
- Blind hole load introduction.
- W&M certified.
- Optional overload stop.
- Extremely rugged design.
- Easy installation by welding.

**Dimensions**

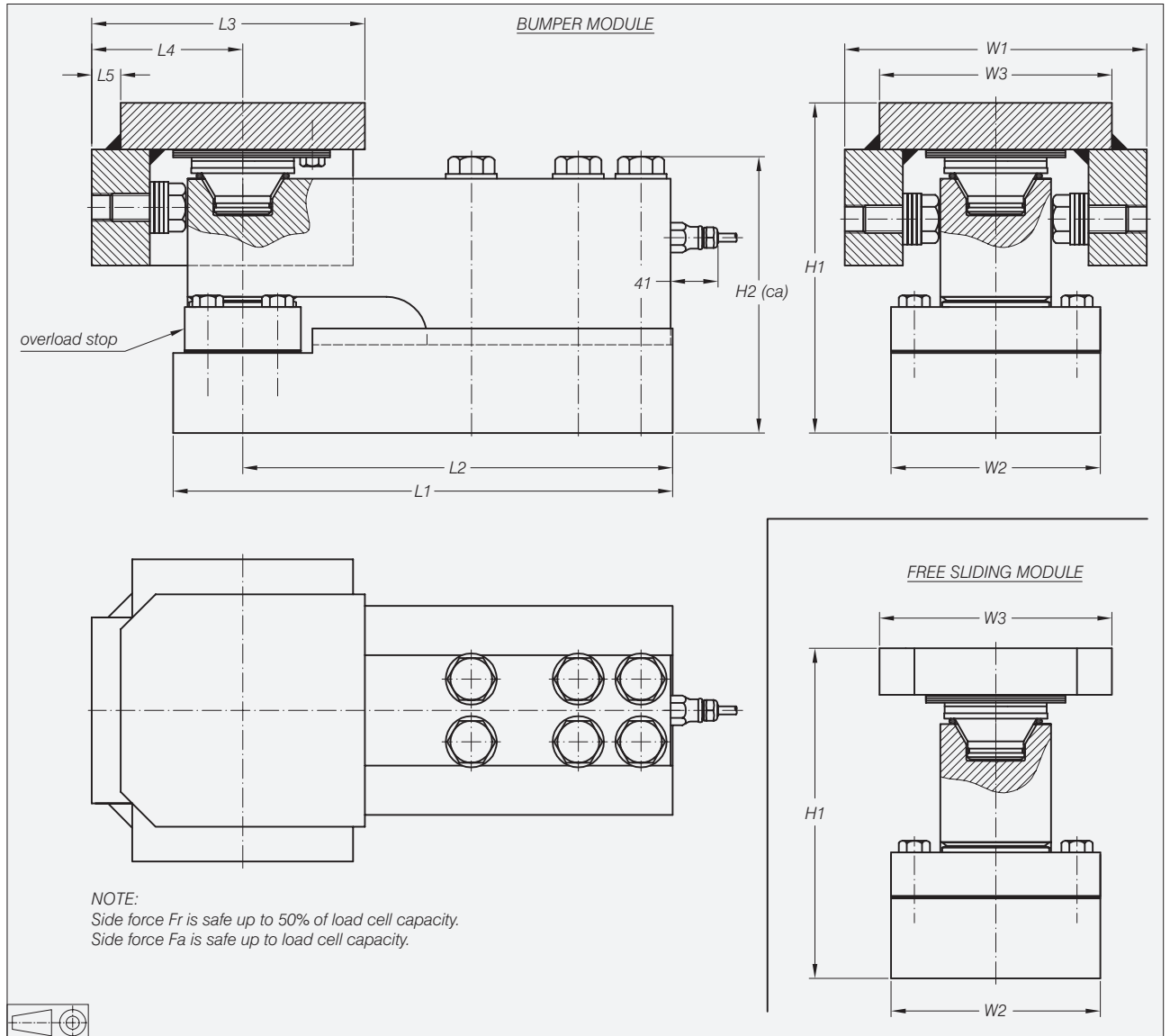

Load cell type	L1	L2	L3	L4	L5	W1	W2	W3	H1	H2	Weight incl. load cell (kg)
SB2-45 klb	320	281	195	91	15	176	150	150	200	171	54
SB2-100 klb	430	370	235	130	25	260	180	200	284	238	128

All dimensions in mm. Dimensions and specifications are subject to change without notice. CAD files for customer's own application drawings are available on request.

**Orientation of weigh modules**

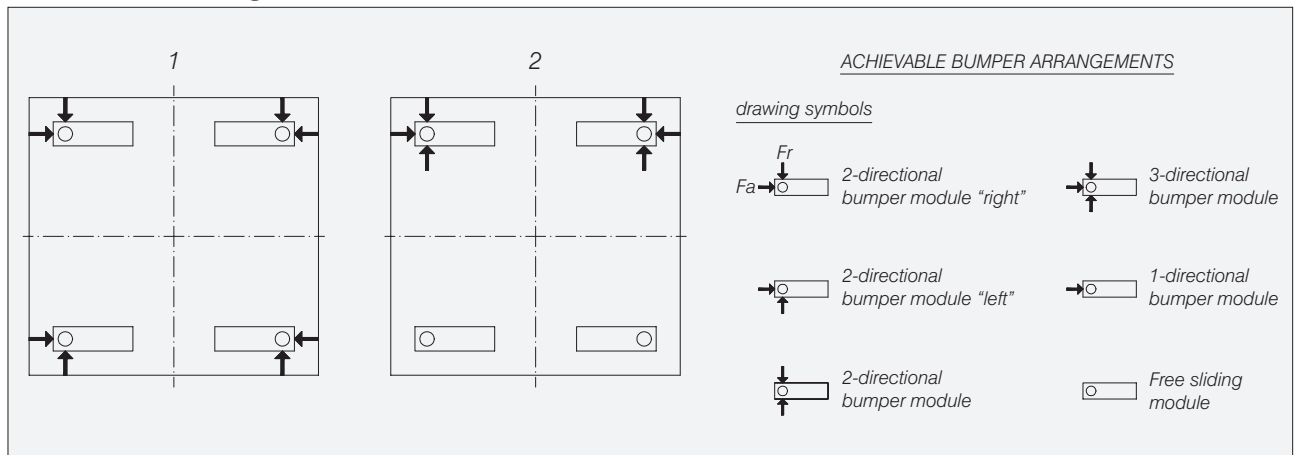

C122 Rev0 UK 2(2)

Beam Type Load Cells