

Type PCB Load Cell



Flintec load cells are designed to meet the most stringent accuracy requirements. Certifications have been obtained from Weights & Measures Authorities, worldwide. PCB load cells are available in the capacities 50 kg to 1000 kg and include Accuracy Classifications GP, C3 and C3 MI 6 according to OIML R 60.

They offer total stainless steel construction and complete hermetic sealing, making them suitable for use in the toughest industrial environments.

Designed to withstand shock and fatigue loading.

Applications are platform scales, hopper and tank weighing systems.

The off center load performance according OIML allows a maximum platform size of 1000 × 1000 mm.

Important Features

- Capacities: 50 kg to 1000 kg.
- High accuracy.
- Total stainless steel construction.
- Complete hermetic sealing.
- Protection IP 68.
- Maximum platform size 1000 × 1000 mm.
- High input resistance: 1100 Ω.
- No additional flexures required.
- Easy cable replacement.
- Factory mutual approved.

Option

- Explosion proof EEx ia IIC T6...T4.

PCB Specifications

Maximum capacity (=E _{max})	kg	50 / 100 / 250 / 500 / 1000	250 / 500 / 1000	
Rated Output (=RO)	mV/V	2 ± 5%		
Accuracy class according to OIML R 60		(GP)	C3	C3 MI 6
Maximum number of verification intervals (n)		n.a.	3000	3000
Minimum load cell verification interval (v _{min})		n.a.	E _{max} /12500	E _{max} /12500
Combined error	%RO	≤ ± 0.040	≤ ± 0.020	≤ ± 0.020
Creep error (30 minutes)	%RO	≤ ± 0.060	≤ ± 0.024	≤ ± 0.013
Temperature effect on minimum dead load output	%RO/°C	≤ ± 0.0040	≤ ± 0.0011	≤ ± 0.0011
Temperature effect on sensitivity	%/°C	≤ ± 0.0020	≤ ± 0.0011	≤ ± 0.0011
Excitation voltage	V	5...15		
Zero balance	%RO	≤ ± 1.0		
Input resistance	Ω	1106 ± 10		
Output resistance	Ω	960 ± 50		
Insulation resistance	MΩ	≥ 5000		
Compensated temperature range	°C	-10... +40		
Operating temperature range	°C	-40... +80		
Safe load limit	%E _{max}	200		
Ultimate load	%E _{max}	300		
Safe side load	%E _{max}	100		
Maximum platform size; loading according OIML	mm	1000 × 1000		
Maximum off center distance at maximum capacity	mm	400		
Load cell material		stainless steel 17-4 PH (1.4548)		
Sealing		complete hermetic sealing; cable entry sealed by using a glass to metal header		
Protection according DIN 40.050		IP 68		

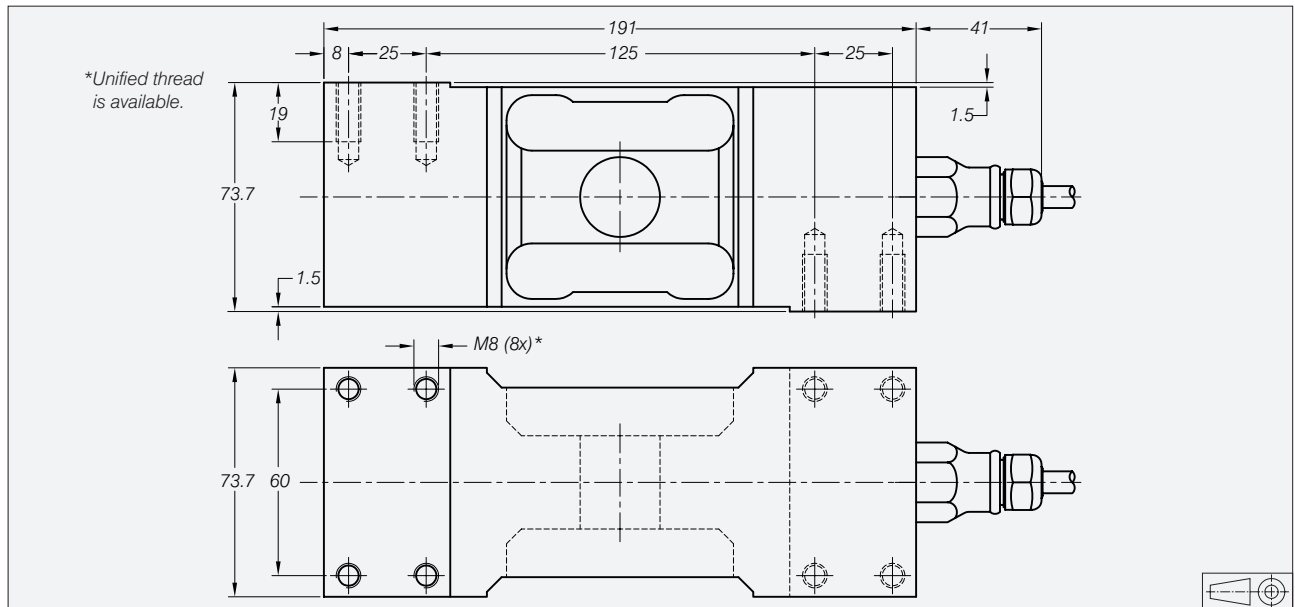

Wiring

- The load cell is provided with a shielded, 4 conductor cable.
- Cable length: 3 m.
- Cable diameter: 5 mm.
- The shield is floating.

